

KOMA[®]
Trim Products

INSTALLATION AND HANDLING GUIDELINES

STORAGE AND HANDLING

- KOMA[®] Trim Products should be stored on a level, flat surface. If stored on an uneven surface for an extended period, some waviness in the boards could occur. This may cause them to be unsuitable for certain applications.
- KOMA[®] Trim Products have one of the hardest and most durable surfaces in the industry and will withstand reasonable handling at the yard level and on the job site. Care should be taken to avoid unnecessary damage.
- KOMA[®] Trim Products are shipped in pallet units enclosed in protective shrouds. After clipping unit bands, continue to use the protective shrouds.
- Additionally, KOMA[®] offers boards in individually shrink wrapped packs to further protect shipped product. Do not remove shrink wrap until ready to install. This will help keep the material free of dirt and debris.

CLEANING

- All exterior building materials require some degree of maintenance and cleaning. Most stains are caused naturally or environmentally and do not constitute a manufacturing defect. Just like wood, KOMA[®] Trim Products are not impervious to grease, mud, bird droppings, or stains resulting from normal use and environmental conditions.
- Below are products that are effective for general cleaning and will not harm KOMA[®] Trim Products surface. The stain or contamination will determine the appropriate selection. Always follow the manufacturers instructions for use and test in an inconspicuous area.
 - Simple Green[™]
 - Soft Scrub[™]
 - Super Clean[™]
 - Clorox Outdoor Bleach Cleaner[™]
 - Jomax[™]
 - Or equal

- Denatured alcohol or mineral spirits can be used to remove smudges left from handling during installation.
- Do not use harsh (aggressive to PVC) solvents such as acetone, toluene, MEK, etc.
- For exceptionally stubborn or ground-in dirt a cleaning solution can be prepared by mixing: 1/3 cup powdered detergent (such as Fab[™] or Tide[™]) and 2/3 cup powdered household cleaner (Spic[™] & Span[™], Soilax[™]) in one gallon of water. Apply the cleaning solution with a stiff-bristled brush (nylon, palmyra fiber, or stainless steel) and rinse thoroughly.
- If mildew is the major problem a solution of 30% vinegar and 70% water will work or a mixture of: 1/3 cup of non-ammoniated powdered detergent, 2/3 cup tri-sodium phosphate (TSP, sold in paint stores) and one quart of chlorine bleach in one gallon of water. Apply the solution with a stiff-bristled brush and rinse thoroughly.

WARNING: NEVER MIX CHLORINE BLEACH WITH AMMONIATED CLEANERS. A DANGEROUS GAS IS PRODUCED!

- KOMA[®] Trim Products can also be cleaned by sanding. See the sanding section for recommendations.

FASTENING

- KOMA[®] Trim Products are non-structural decorative trim.
- Nail guns and fasteners intended for typical wood trim installations will work with KOMA[®] Trim Products.
- Avoid ring-shanked nails as they cause blow out on the back side of installed trim.
- Fasteners should penetrate solid framing substrate at least 1 1/4" and be spaced no farther apart than 16" on center.

Figure 1 on the following page demonstrates proper fastener penetration into substructure.

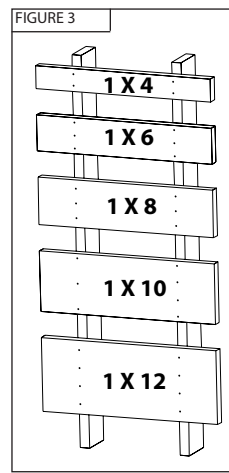
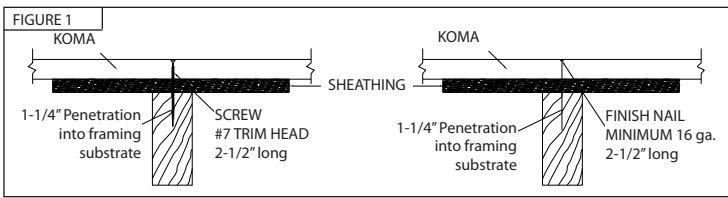

- If gun nailing, make the necessary adjustments (e.g. air pressure, nail gun depth stop) to countersink the head of the nail 1/16” to 1/8” below the surface. Test on pieces of scrap before applying finished product.
- Use non-corrosive fasteners for lasting results. We suggest stainless steel or a coated fastener that has passed ASTM B117 test criteria.
- When hand nailing, avoid striking the board surface with excessive force.
- Where possible, glue KOMA® Trim Products to the substrate using construction adhesives identified for use with PVC (**see Figure 4**). Always read the adhesive label or check with the manufacturer to confirm that the adhesive is appropriate for use with PVC.
- Note: Adhesive assists in minimizing installed boards thermal movement. Adhesive should never be used as a substitute for proper nailing schedule.
- Use accepted trim installation nailing schedules based upon standard residential light frame construction layout. Wider boards will require additional fasteners at each fastening location.

Figure 2 specifies the number of fasteners required at each attachment location. (16” on center spacing maximum)

- Provide adequate blocking at all joints. Do not use scarf joints to join boards in long runs, e.g., fascia, frieze, rake, or band boards.

- Pre-drilling KOMA® Trim Products may be necessary when using large diameter fasteners or when installing in low temperatures.
- When applying more than three fasteners to a board in the same stud/blocking location, slightly stagger the line of the fasteners.

SPANNING

- KOMA® Trim Products are decorative trim and should not be used as load bearing elements or assemblies or for structural applications.
- Never install KOMA® Trim Products to a span greater than 16”.
- Fasten KOMA® Edge & Center Bead every 12” to 16”. Always install KOMA® Edge & Center Bead at right angles to the framing. Fasten Koma Beaded Sheets with one fastener per every square foot of installed surface area.
- When spanning greater than 16”, install blocking and bracing. In the case of spanning/covering rafter tails with spacing greater than 16” o.c., install a continuous sub-fascia onto which the KOMA® trim boards and other elements (eg., moldings, decorative brackets, etc.) will be fastened.

THERMAL MOVEMENT

- KOMA® Trim Products are polymer based and will expand and contract with changes in temperature.
- Adequate fastening of KOMA® Trim Products will minimize the movement that occurs due to changes in temperature. Where possible, adhere KOMA® Trim Products to the substrate/

FIGURE 2

Fasteners required at each attachment location. (16” on center spacing maximum)

BOARD WIDTH	15 GA (0.072”)	14 GA (0.080”)	13 GA (0.0915”)	12 GA (0.1055”)	7P Finish	#7 (min.) Trim Head Screw
3 1/2” (1 x 4)	3	3	3	3	3	2
5 1/2” (1 x 6)	3	3	3	3	3	3
7 1/4” (1 x 8)	3	3	3	3	3	3
9 1/4” (1 x 10)	4	4	4	4	4	3
11 1/4” (1 x 12)	4	4	4	4	4	4

FIGURE 4 ADHESIVE CHART

Type of Adhesive	Brand	Supplier	Function/Application	Properties/Characteristics
Toughened Acrylics	Bond & Fill	KOMA® Trim Products (Huntsville, AL.) 800/330/2239 www.komatrimboards.com	Bonding KOMA to KOMA, excellent for filling fastener holes. Color matched to KOMA with UV stabilizer. Standard formulation cures in 15-20 minutes; 5 Minute fast-cure formula available. Delivered through a mixing nozzle from a plural component gun.	Plural component, fast curing, high strength, more flexible than epoxies
Construction Adhesive	PL Polyurethane Premium Construction Adhesive	Henkel Corporation (Mentor, OH) 800/624/7767 www.stickwithpl.com	Attaching trim to substructure and sheathing. PI formulation is polyurethane enhanced for superior elongation and long-term flexibility. Applied from cartridge using standard caulking gun.	Flexibility, impact resistance, durability
Solvent/Welding Cement	TrimTight™	TrimGlue, Inc. 877-874-5455 www.trimtight.com	Welding KOMA to KOMA; dries opaque off-white. Applied by brush. Available in numerous size cans (smallest with applicator brush). Water clean-up.	Medium body, clear, one-step self priming, cleans up with water
	Christy's Super Hot White Vinyl	T. Christy Enterprises, Inc. (Anahiem, CA) 715/507/3300 www.tchristy.com	Welding KOMA to KOMA, UV stabilized, white, excellent gap filling and for making repairs.	Single component comprised of resins and solvents

Notes: The bonding agents listed above have produced excellent results for each category of application. Always test prior to use to determine suitability and read and follow adhesive manufacturers' instructions. We encourage other suppliers to provide test data showing equivalent or superior performance and we will include them in next printing, other technical bulletins, and training/educational materials.

substructure. We suggest using construction adhesive on the back of KOMA® Trim Products (see "Adhesive Chart" Figure 4) in addition to mechanical fasteners ("fastening schedule" outlined in fastening).

- Apply construction adhesive in a stop start diagonal line pattern with a bead size of 1/4" – 3/8" diameter on to the substrate area the KOMA® Trim Products will cover.
- Properly bonding joints between pieces of KOMA® Trim Products with a suitable structural adhesive or welding cement (see figure 6) will minimize or discourage separation and unsightly gaps.
- Positioning expansion joints along runs >36' can accommodate movement that occurs due to changes in temperature.

Figure 5 is a cross-section of an expansion/control joint.

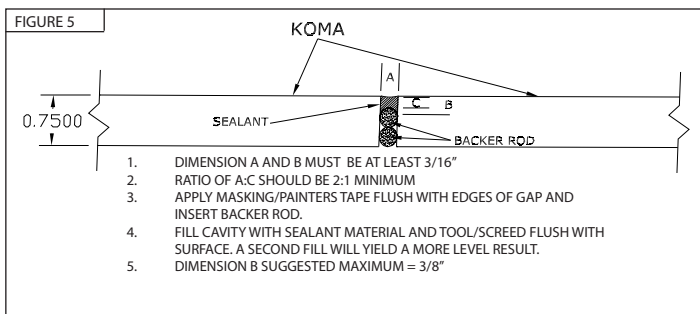

(If you have any questions pertaining to these situations or applications please call technical support at Kommerling USA (800/330-2239).

GLUING

- To achieve optimum KOMA® to KOMA® bonds, the mating surfaces should be clean, dry, and free from contamination.
- We suggest using KOMA® Bond & Fill or a first quality welding adhesive identified for use with PVC for edge-to-edge, edge-to-face, and face-to-face bonding of KOMA® to KOMA®. Take caution to not over-clamp edge to edge bonds. A film layer is necessary for strongest bond.
- Use square cut butt joints to join KOMA® to KOMA® on long runs such as fascia, frieze, and rakes.
- Fasten KOMA® Trim Products securely on both sides of the glued joint to ensure adequate cure time. Fasteners should be >1/2" from end or edge of material.

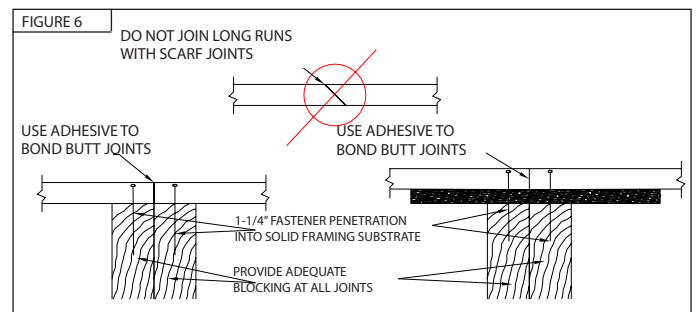

Figure 6 demonstrating correct nail proximity to board to board attachments.

- Do not use acrylic painters caulk or silicone caulk. They will not adhere long term and will contaminate gaps and joints when you attempt to correct their lack of performance.

SAWING AND CUTTING

- KOMA® Trim Products can be cut using the same saws normally used for cutting wood; e.g., circular, miter, radial, table, panel, band, jig, and industrial gang rip. It is important that the cutting blades be good quality, clean and sharp. TCT (tungsten carbide tipped) blades with a high alternate top bevel (hiATB) or triple chip grind (TCG) yield the best results. Choose 10" blades with 80 teeth or 12" blades with 96 teeth for a smoother edge finish.
- Maintain a feed/rpm rate that allows for efficient chip removal. Always position the stock so that the teeth are cutting into the good or "finished" face.
- Use of fine toothed blades is not recommended.
- Following these general work practices will improve results:
 - Plastics absorb heat and care must be taken not to overheat the work piece. Feed rates are important. Too slow a feed rate will result in teeth rubbing rather than cutting, creating friction and melting the chips. Rates will vary with material thickness, geometry of cutting teeth, and speed of blade rotation (rpm). Always run test pieces to determine optimum performance.
 - Plastics are not as stiff as some other materials. Adequate support should be provided for the work piece. Always secure the stock before cutting. When rip cutting, use a rip guide or secure a straight edge to use as a cutting guide.

PAINTING

- KOMA® Trim Products do not require paint for protection from the elements (sunlight, rain, insects). However, when painted, PVC trim will rinse cleaner and be less prone to attract dirt and stains that are caused by environmental conditions.
- If painting is desired to achieve a custom color, use a 100% acrylic latex paint with a LRV (Light Reflective Value) of 55 or higher.
- No special preparation or priming is required prior to painting. The KOMA® Trim Products surface should be clean and dry.
- KOMA® Trim Products do not absorb moisture. Paints will last longer on KOMA® than on wood since moisture cycling does not occur.
- Always follow the paint manufacturers recommendations.
- Factory finishing by independent coaters is available in some areas. Call KOMA® technical support for referrals.

NOTE: Compared to PVC trim produced with free foam technology, most users will appreciate the immediate and long-term adhesion advantage of KOMA®'s celuka technology PVC trim products. Simply stated, paints commonly cover KOMA®'s celuka sheet and boards on the first coat and are more scuff and scratch resistant.

SANDING (The sanding section does not apply to KOMA MW product.)

- KOMA® Trimboards may be sanded with any type of sander. To maintain the proprietary KOMA® surface texture, it is recommended to use a block or belt sander and sand in the direction of the "grain". Use 120 grit paper and apply light pressure. Practice on a scrap piece of KOMA® until the desired result is obtained. When it is necessary to cut or trim Koma at the job site for a custom fit, a belt or pad sander may be used to smooth the edges.

DRILLING

- Holes can be drilled with standard steel twist drills. They should be sharp with an included point angle of between 100° and 120°, a spiral angle of 30°, and a relief angle of 10°.
- When drilling, it is important to ensure good chip removal to avoid overheating the hole walls and causing a build up on the drill. This can be accomplished by drilling with a peck or "woodpecker" method, alternately plunging and withdrawing the drill to clear chips..
- Drills ground for rigid PVC are not necessary or recommended.

ROUTING

- KOMA® Trim Products boards can be routed as easily as wood and with the same equipment and tools. Standard carbide tipped router bits with multiple flutes work best when using hand-held routers.
- Dimensional consistency and uniform thickness of KOMA® Trim Products enable it to be machined to tighter tolerances than wood. This is an advantage when milling with CNC equipment or when performing repetitive fixture builds.
- Koma offers Koma MW, a millwork grade product with a finer cell structure making it ideal for routing and heavier profiling.

For specific tooling recommendations, feeds, and speeds, please call technical support at Kommerling USA. (800-330-2239)

KOMA®
Trim Products

1-800-330-2239
komatrimboards.com

IHG 02/09-01