

REV	DESCRIPTION	DATE	APPROVED
A	RELEASE DRAWING INTO DRAWING LOG	-	P. BERNAL
B	UPDATED DRAWING TO REFLECT NEW TOLERANCE. WIDTH TOLERANCE CHANGE TO $\pm 1/4"$ AND HEIGHT TOLERANCE CHANGE TO $\pm 1/8"$	01/25/19	P. BERNAL

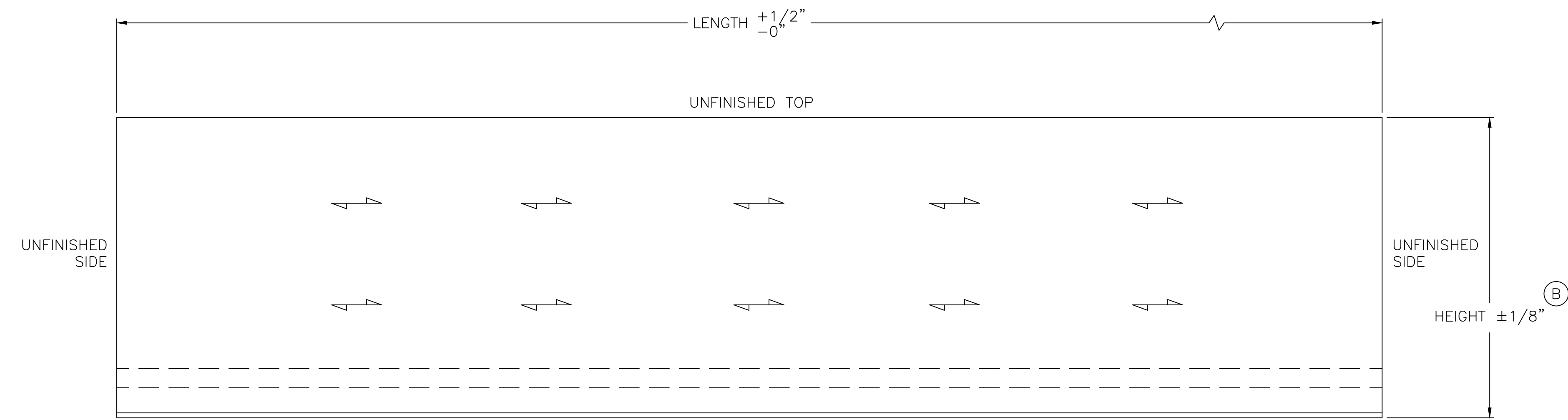
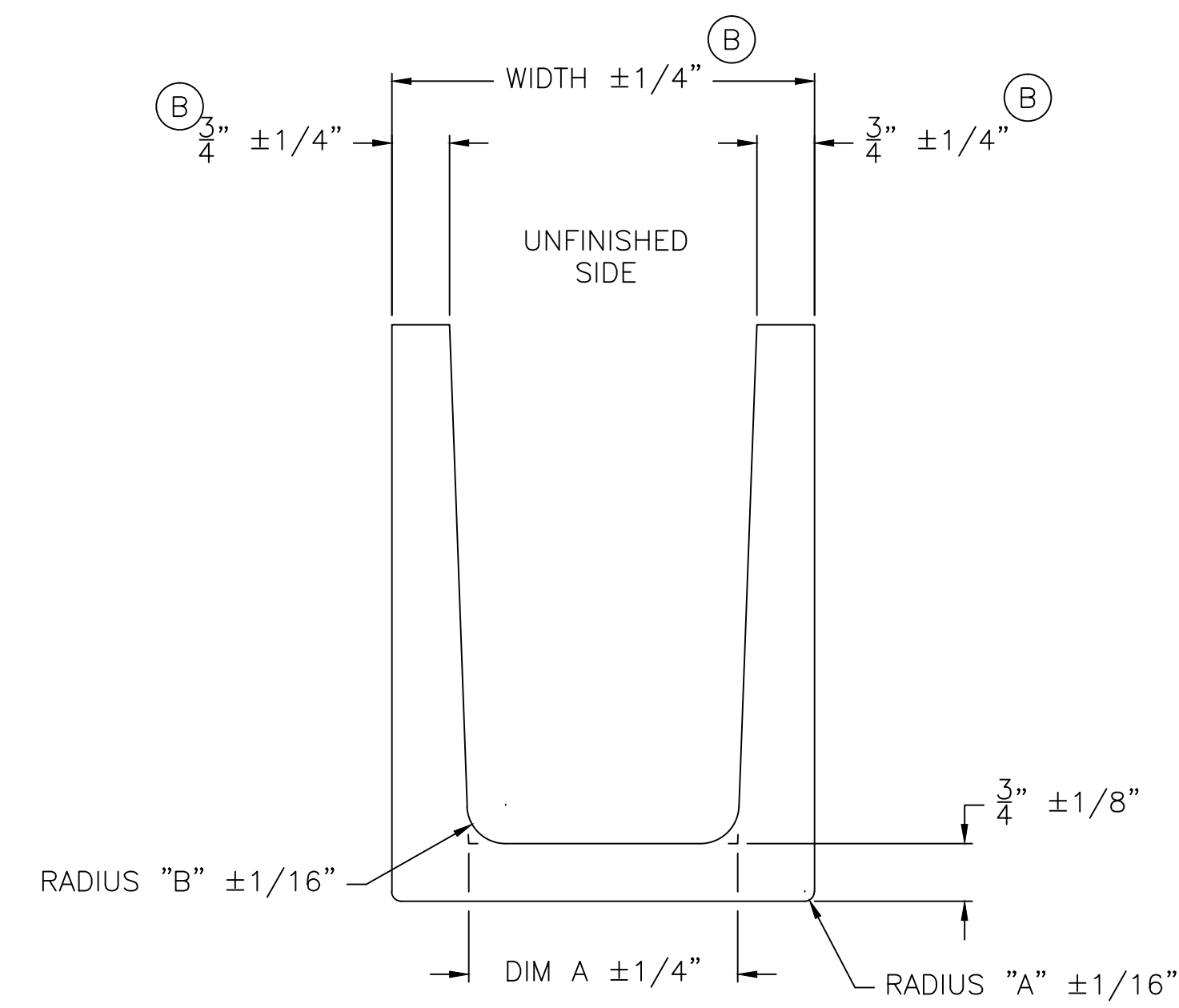
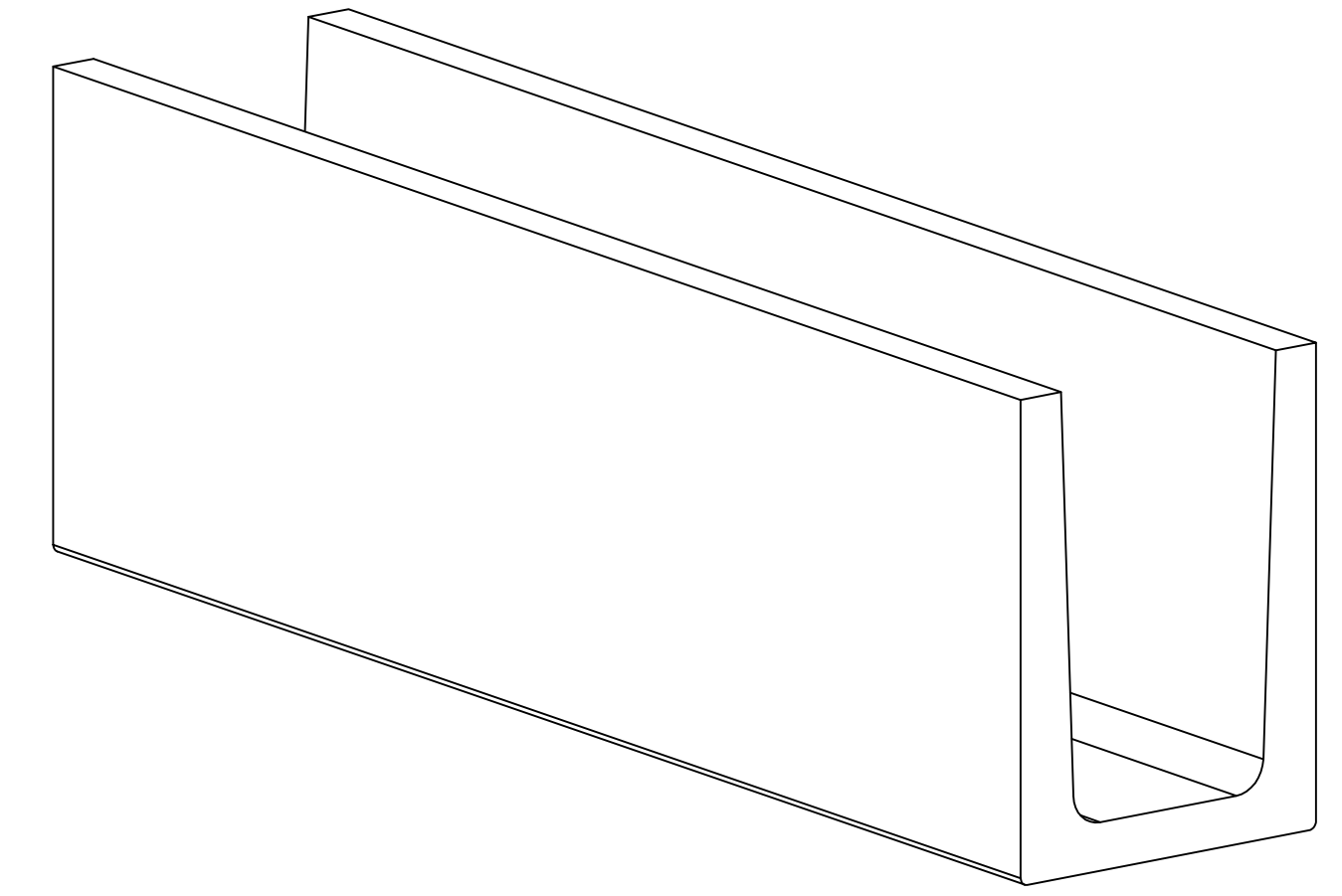

- NOTES:
1. MATERIAL CLOSED CELL POLYURETHANE PER MS0072.
 2. FOR WOODGRAIN FINISH TAN COLOR PARTS PRIME WITH SHERWIN WILLIAMS E60NP00101-V03 OR EQUIVALENT.
 3. REFERENCE MATH DATA FOR ALL UNDIMENSIONED FEATURES.
 4. SEE PART NUMBER LOGIC FOR ALL BEAMS.
 5. ARROWS INDICATES WOODGRAIN DIRECTION.
 6. DRAFT ANGLE PERMISSIBLE FOR MATERIAL SAVER
 7. MATERIAL SAVER CAN BE OFF CENTER $\pm .250$ IN.
 8. FOR TEXTURED PARTS REFERENCE MS0080.

BEAM DIMENSIONS

NOMINAL	WIDTH	HEIGHT	LENGTH	DIM A	RADIUS A	RADIUS B	TEXTURE
4"x6"	3-1/2"	5-1/2"	FROM 96" TO 288", IN 24" INCREMENTS	1-5/8"	1/8"	1/4"	MESA
6"x8"	5-1/2"	7-1/2"		3-1/2"	3/8"	1/2"	MESA
8"x10"	7-1/2"	9-1/2"		5-3/8"	3/8"	1/2"	MESA
10"x15"	9-1/8"	14-3/4"		6-5/8"	1/2"	1/2"	MESA
4"x6"	3-1/2"	5-1/2"		1-5/8"	1/8"	1/4"	TAHDE
6"x8"	5-1/2"	7-1/2"		3-1/2"	3/8"	1/2"	TAHDE
8"x10"	7-1/2"	9-1/2"		5-3/8"	3/8"	1/2"	TAHDE
4"x6"	3-1/2"	5-1/2"		1-5/8"	1/8"	1/4"	ROUGH SAWN
6"x8"	5-1/2"	7-1/2"		3-1/2"	1/8"	1/2"	ROUGH SAWN
8"x10"	7-1/2"	9-1/2"		5-3/8"	1/8"	1/2"	ROUGH SAWN
4"x6"	3-1/2"	5-1/2"	1-5/8"	1/8"	1/4"	HAND HEWN	
6"x8"	5-1/2"	7-1/2"	3-1/2"	1/8"	1/2"	HAND HEWN	
8"x10"	7-1/2"	9-1/2"	5-3/8"	1/8"	1/2"	HAND HEWN	

FYPON

TITLE **TIMBER WOODGRAIN BEAM**

SIZE D	QUOTED ITEM NUMBER	DRWG NO.	REV B
DRAWN BY Z. WALK	DATE 09/02/15	CHECKED BY	CHECKED BY
SCALE NTS	DO NOT SCALE DRAWING	SHEET 1 OF 2	

UNLESS OTHERWISE SPECIFIED, ALL DIMENSIONS ARE IN INCHES

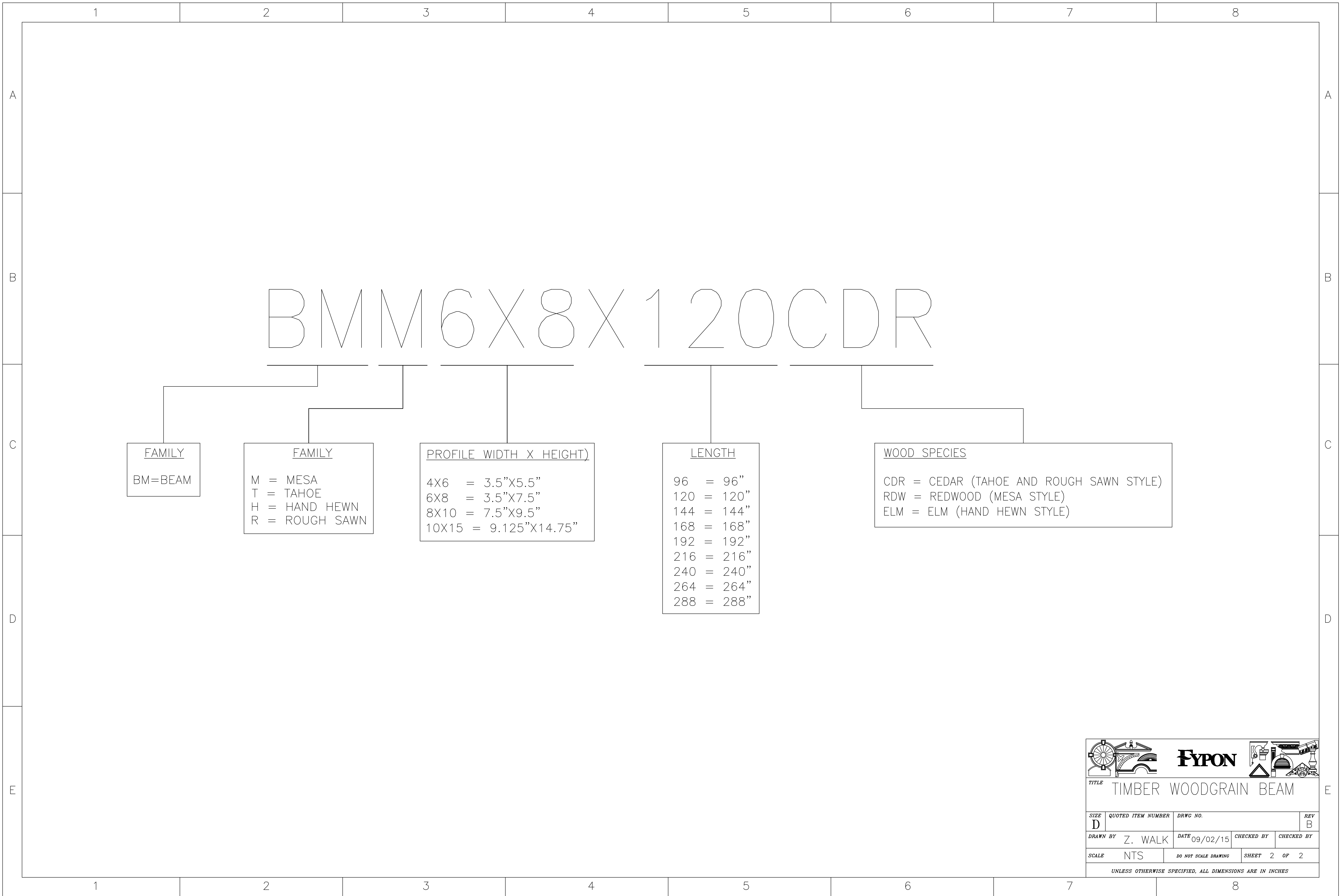

BMM6X8X120CDR

FAMILY
BM=BEAM

FAMILY
M = MESA
T = TAHOE
H = HAND HEWN
R = ROUGH SAWN

PROFILE WIDTH X HEIGHT)
4X6 = 3.5"X5.5"
6X8 = 3.5"X7.5"
8X10 = 7.5"X9.5"
10X15 = 9.125"X14.75"

LENGTH
96 = 96"
120 = 120"
144 = 144"
168 = 168"
192 = 192"
216 = 216"
240 = 240"
264 = 264"
288 = 288"

WOOD SPECIES
CDR = CEDAR (TAHOE AND ROUGH SAWN STYLE)
RDW = REDWOOD (MESA STYLE)
ELM = ELM (HAND HEWN STYLE)



TITLE TIMBER WOODGRAIN BEAM

SIZE D	QUOTED ITEM NUMBER	DRWG NO.	REV B
DRAWN BY Z. WALK	DATE 09/02/15	CHECKED BY	CHECKED BY
SCALE NTS	DO NOT SCALE DRAWING	SHEET 2 OF 2	

UNLESS OTHERWISE SPECIFIED, ALL DIMENSIONS ARE IN INCHES